

S202-S202M SINGLE CIRCUIT

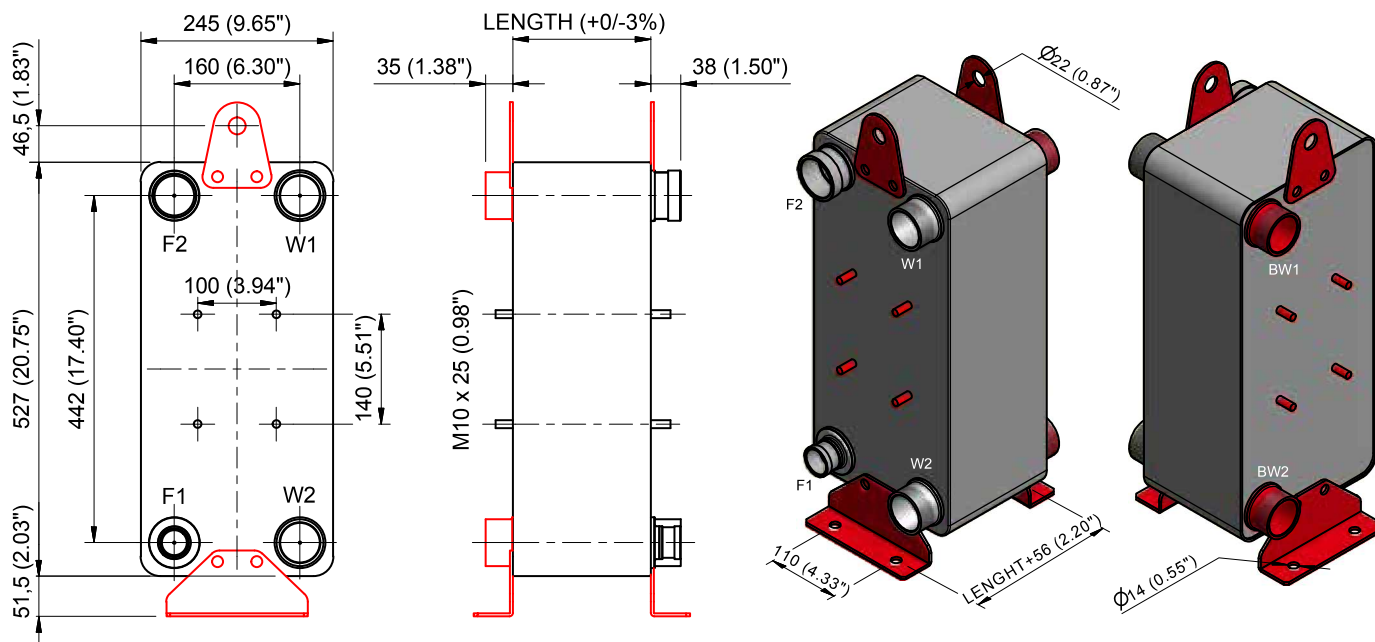

Pioli e staffe come optional

F1 INLET Refrigerant W1-BW1 INLET Secondary Fluid
 F2 OUTLET Refrigerant W2-BW2 OUTLET Secondary Fluid

SPECIFICATIONS	S202	S202H
PS (bar)	30	45
TEMPERATURE RANGE (°C)	-100°C to +120°C	-100°C to +120°C
MAXIMUM CONNECTIONS AVAILABLE (mm)	57	57
MAXIMUM FLOW RATE (m3/h)	50,62	50,62
VOLUME / CHANNEL (liters)	0,269	0,269
DIMENSIONS (mm)	245 x 527	245 x 527
LENGHT CALCULATION (mm)	$N \times 2,35 + 12$	$N \times 2,35 + 16$
WEIGHT CALCULATION (kg)	$N \times 0,4 + 10$	$N \times 0,4 + 14$

CONNECTIONS TYPE					
Soldering	Threaded M	Threaded F	Grooved	Rotalock	Flanges
S22	C48	F48	V50	R32	CF66
S28	IC48	F60	V65	R44	
S35	C60	IF48		R58	
S42	IC60	IF60			
S54	G48				
S60	G60				
	G70				
Standard Connections: F1 S35 F2 S54 W1-W2 C60					
FOR SPECIAL CONNECTIONS SEE PAGE 19 AND 20					

N Number of plates

LETTER TO IDENTIFY CONNECTIONS TYPE

- S** Soldering Connections
- C** Conical Male Gas Threaded Connections
- G** Cylindric Male Gas Threaded Connections
- F** Female Gas Threaded Connections
- V-BV** Grooved System for Standard Flexible Coupling
- R** Rotalock Connections Male

EXCHANGE PLATE MATERIAL Stainless Steel 316L

BRAZING MATERIAL Copper (Cu)